

**Meter connection pillar 2-bay, H=2010mm, 2-3.HZ,
hood closed.**

Order number: 7160151

Type: ZSA202-2-2ZK-APZ-TSG

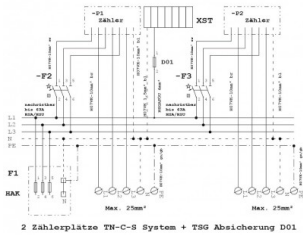

Equipment

- House connection box NH00/3
- Connection compartment 5 x busbars with:
 - Connection terminal, preparation for 2 x main circuit breakers
 - Cover with cut-out for 2 x SH switches
- 2 x meter plate 450 x 250 mm with IP54 cover
- Connection compartment 150 x 250 mm with:
 - 1 x TSG fuse D01 1-pole 10A, sealable cover
- Connection compartment 300 x 250 mm with:
 - 2 x main line branch terminal 5-pole 25 mm² insulated
- Connection compartment 300 x 250 mm prepared for APZ:
 - 1 x RJ45 socket, 1 x mounting plate, 1 x top hat rail
- With double lock including 1 cylinder built in

Dimensions

Depth	277,5 mm
Height	2010 mm
Width	583 mm

Properties

Colour	RAL 7035
Degree of protection (IP)	IP54
Power type	TN-C-S network

Certificates & standards

REACH	false
RoHS	true / exception 6c

Circuit diagram

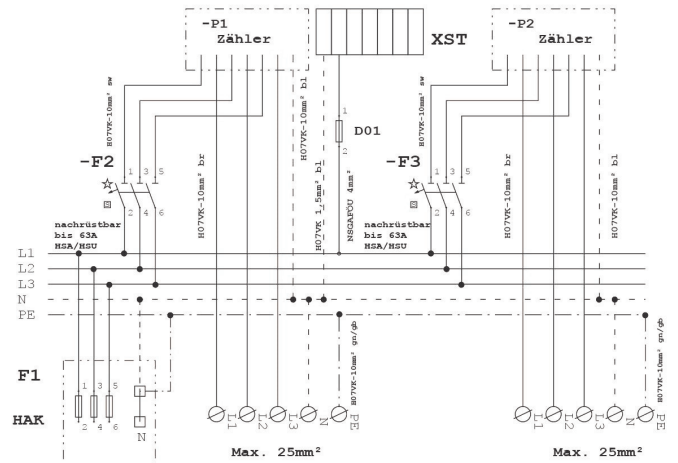

2 Zählerplätze TN-C-S System + TSG Absicherung D01